

Briquetting

*Granulation
by compacting*

Grinding



SAHUT-CONREUR

SAHUT-CONREUR :

Experience

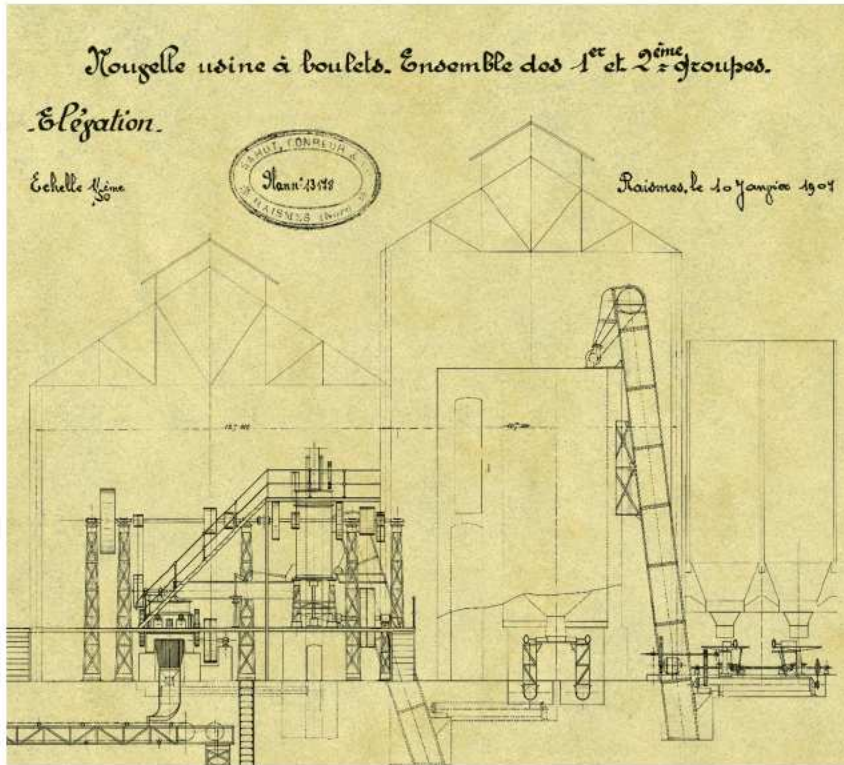

In 1859, Alfred CONREUR established a mechanical workshop in Raismes, in the North of France. Since the first decades of the 20th century, the SAHUT-CONREUR company has then specialized in the design and construction of coal briquetting plants using double roll presses. Beginning in the 1950's, the company expanded this technology for new fields of applications concerning a variety of industries : chemical, food processing, iron and steel, metallurgical, nuclear, ores and minerals, pharmaceutical... and many other powder processing industries.

In addition to the double roll press, the company has developed a range of additional equipments specifically adapted to the requirements of this technology : mixers, pug-mills, flake-breakers, hammer-mills, granulators, etc...

After more than a century of existence, SAHUT-CONREUR is recognized as one of the world leaders in the engineering and construction of briquetting and granulation by compaction plants. Furthermore in the 1980's, SAHUT-CONREUR has expanded the use of roller presses to grinding by double rolls.

Know-how

SAHUT-CONREUR's know-how was obtained with the help of the pilot plant, the toll production unit, the engineering department, the manufacturing workshop and the achievement of numerous plants.

The pilot plant is a true means of research and development, with a full range of lab equipments necessary to determine the key parameters that will be used in the design of equipments and plants.

This design work performed through CAD work-stations by the engineering department is adapted to the requirements of each user. Equipped with special machinery for the manufacture of presses and ancillary equipments, the workshop meets the reliability

and quality standards of production and provides a full autonomy to SAHUT-CONREUR.



Shaping the future

Quality and Service

A constant search for technical innovations and a modernization of CAD workstations and machining centers ensure the quality and reliability of the plants installed by SAHUT-CONREUR.

With its engineers and skilled technicians SAHUT-CONREUR will assist customers from design through start-up of their plant and training of staff and throughout the plant operation.

Internationalization

The equipments manufactured by SAHUT-CONREUR are delivered to all five continents. Export sales account for more than 80 % of total sales.

A network of sales agents and associated companies represent the company in more than 30 countries and are at your service to give information on the know-how and services we can provide and answer your requests.

We also participate in many important international exhibitions of major industries.



*Experience, know-how, service,
SAHUT-CONREUR has all the necessary means
to propose a global solution and implement it.*

Compaction - Why ?

Briquetting (briquettes), and granulation by compacting (granules) processes are technologies of particle size enlargement using a dry process in which dusts or powders are formed into shapes. The densification of the product is obtained by mechanical compression through a double roll press.

A TECHNICAL SOLUTION

- Obtain products of the same size, volume and weight :
an agglomerate/a compact can represent the exact dose required in a process
- Obtain a specified and constant product size-range
- Reduce the volume of a powder
- Stabilize mixtures of powders : during handling and transport, the heterogeneous mixtures of particles lose their uniformity because of the variation in density, shape and size of the particles. The problems of segregation disappear
- Improve the flowability of the powders, thus preventing problems of feed, dosage or packaging
- Improve the compactability of some powders
- Eliminate the problems of dust generation during handling
- Control the hardness and strength of products
- Control the dispersion rate of granules
- Solve the problems of powder caking during storage



A COMMERCIAL-MARKETING SOLUTION

- Increase the sales appeal of a product
- Facilitate dosage use : an agglomerate can represent the exact dose required in a process for ease of exact dosage





AN ENVIRONMENTAL SOLUTION

- *Recycle industrial waste*
- *Recycle beneficiated dust in an industrial process*
- *Eliminate pollution problems caused by airborne dust : air and ground pollution*

AN ECONOMICAL SOLUTION

- *Replace the wet process of agglomeration involving costly drying and binder addition techniques*
- *Allow more flexibility in the choice of raw materials purchased at the most attractive price (compound fertilisers)*
- *Adapt easily and quickly to a wider range of mixed fertilizer formulas*
- *Granule products that cannot be granulated by means of other techniques (wet process)*
- *Upgrade by-products*
- *Reduce the packing, storage and transport costs thanks to a volume reduction and higher density of the product*
- *Avoid loss of product in dust form*



The Double



SAHUT-CONREUR designs and manufactures double-roll presses for heavy-duty operation under hard and difficult conditions ; reliable use and minimal maintenance are basic criteria for the design of these presses. The main components of the double roll presses (also called briquetters or compactors) are :

FEED SYSTEM OF THE ROLLS

The feed system is essential for full press efficiency : SAHUT-CONREUR has developed various types of systems selected according to the product processed.

a) The hopper

Feeding the rolls by gravity, this system can, if necessary, be fitted with inclined flaps the position of which is manually or automatically adjusted.

b) The distributor and feed-box

This patented system provides a uniform distribution of material across the roll width : this condition is essential in order to obtain the same agglomerate quality.

c) The force-feeder equipped with one or two conical screws

Predensifying the product and feeding the rolls. For very aerated products, the force-feeder is equipped with a deaeration device (vacuum pump) to remove the air contained in the product

All these feed systems can be equipped with special floating cheek plates reducing the powder leakage on the roll sides and providing a better efficiency in the compaction area.

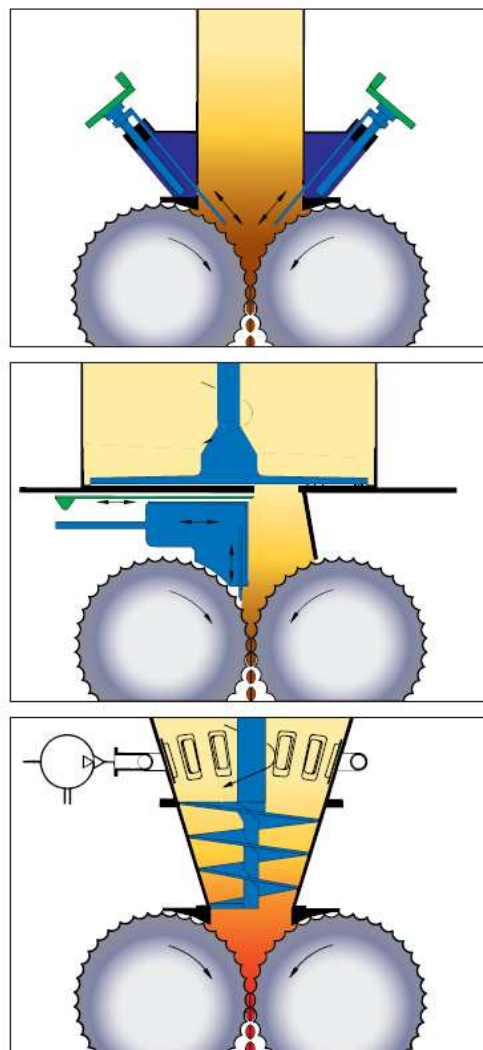

ROLLS

The press is composed of two rolls : one is fixed in the press frame (fixed roll) whereas the other roll can move perpendicular to its axis (mobile roll). The size of a press is characterized among other features by the roll diameter (from 250 mm to 1400 mm) and the roll width (from 40 mm to 1600 mm).

The tangential speed of the rolls determines the compression time which has a noticeable influence on the quality of the densified product : the compression time should increase as the ratio of the apparent density to the true density of the feed decreases, ie when the quantity of air contained in the product increases. The roll speed can go up to 25 Rpm and even higher in particular cases ; it corresponds to a tangential roll speed up to 1 metre per second.



Roll Press

Four technological solutions are possible for the working surface of the rolls :

- shafts with pocketed tyres (steel rings heat-shrunk on the shafts)
- shafts with profiled tyres
- shafts with bolted segments
- profiled monobloc shafts

A number of specifically treated materials are used (alloy steel, stainless steel, cast iron, ...) are used for the manufacture of tyres and segments. Their selection is dictated by the product abrasiveness, its corrosive effect and the conditions of agglomeration (product temperature, compaction pressure).

The patterns on the roll surface has an effect on the performance and the throughput of the press and several patterns are proposed : pocketed, smooth, knurled, corrugated, chevron, ...

The pockets are machined by milling or electrochemical machining (ECM).

The rolls are mounted on double-row self aligning roller-bearings, manually or automatically lubricated by grease or oil.



ROLLS DRIVE

Most of the presses are equipped with a special double-output gear-box and internal gear couplings able to withstand the axial misalignment caused by the mobile roll movement. The coupling of the mobile roll can be fitted with a device for circumferential adjustment of the rolls that provides a perfect synchronization between the fixed roll pockets and those of the mobile roll.

In particular cases (high torque, restricted space, ...) other drive systems (planetary gear-box, hydraulic motor) can be used.

HYDRAULIC SYSTEM

The press is equipped with an hydraulic system able to apply a force on the mobile roll by means of jacks. This force can be different in certain cases on each bearing block of the mobile roll thanks to a double hydraulic circuit. This system also includes safety devices and nitrogen accumulators to dampen the movement and quick return of the mobile roll and protect the press when tramp material is inadvertently fed to the rolls. The force applied on the product can vary from 1 to 150 kN per linear centimetre of roll width and even higher in particular instances.

CONTROL - AUTOMATION

The press is equipped with sensors and a control system which ensure a continuous production of compacts of constant quality without the need for operators.

This system can be :

- either the control between the power consumed by the roll drive and the force-feeder screw speed ;
- or the control between the gap measurement (distance between the rolls) and the force-feeder roll speed ;

SAHUT-CONREUR can propose a complete range of presses : from lab presses to industrial presses of high capacity, each one is specifically adapted to one application.

Fields of application

- Chemicals (sodium sulphate, sodium chloride, carbonates, sodium cyanide, potassium cyanide, iron sulphate, potassium bromide, boric acid, urea, calcium hypochlorite, ...).
- Minerals (alumina, bauxite, lime, dolomite, china clay, magnesia, fluorspar, paint pigments, sulphur,...).
- Gypsum from power station flue gas desulphurisation
- Minerals (chromium, cobalt, copper, iron, manganese, lead, zinc, ...)
- Sponge Iron
- Metallic oxides (Waelz oxides, rare earth oxides, zirconium hydroxide, ferro-alloys, molybdenum trioxide, zircon sand,...)
- Steel turnings
- Coal : production of briquettes for home heating or industrial purpose (partial coke oven charge, briquettes treated to obtain formcoke, briquettes for gasification).
- Coal for production of activated carbon
- Lignite, peat,...
- Charcoal
- Graphite, carbon black
- Coke paste
- Phosphate (hot or cold briquetting)
- Clay
- Detergents
- Frozen food
- Sugar
- Glass batch
- Steelworks waste materials and by-products (sludge, mill dust, sintering fines, mill scale, coke fines,...)
- Dried sewage sludge
- ...

P R O

The briquetting units shape fine materials into larger forms of varied shapes, sizes and volumes (from a few cc up to 600 cc and more) : these characteristics are defined according to the product end use.

If the cohesive forces (particulate cohesion, valence forces, recrystallization, van Der Waals forces...) between the particles are low, a binder has to be used before agglomeration. The physical properties of the feed material, the end use of the briquettes and the cost of binder addition have to be taken into account before a selection is made. A large variety of (liquid or solid) binders is offered : starch, bentonite, bitumen, lime, cement, water, flour, lignosulphonates, molasses, polymer, resin, sodium silicate, etc...

The briquettes are obtained at a low or high pressure and can undergo mechanical or thermal treatment according to the characteristics of the processed material, the binder used and the desired end product.



Considering the large variety of products to be processed and the binders used, the range of mixers designed and proposed by SAHUT-CONREUR is specifically adapted to each type of briquetting :

C E S S



- vertical mixers or pug mills, for instance for briquetting of coal with bitumen.
- twin screw mixers, for instance for briquetting of some chemicals with water ; these mixers can be equipped with heating or cooling jacket, as the case may be.
- horizontal or ploughshare mixers, for instance for briquetting of some minerals with molasses ; these mixers can also be equipped with heating or cooling jacket, as the case may be.



PROCESS

According to the material, the main stages of the process can be as follows :

- Product preparation unit (screening-crushing, drying, sieving).
- Dosing and mixing of product with binder
- Briquetting unit.
- Post treatment of the briquettes (air or oven drying, curing, polymerization, aging).

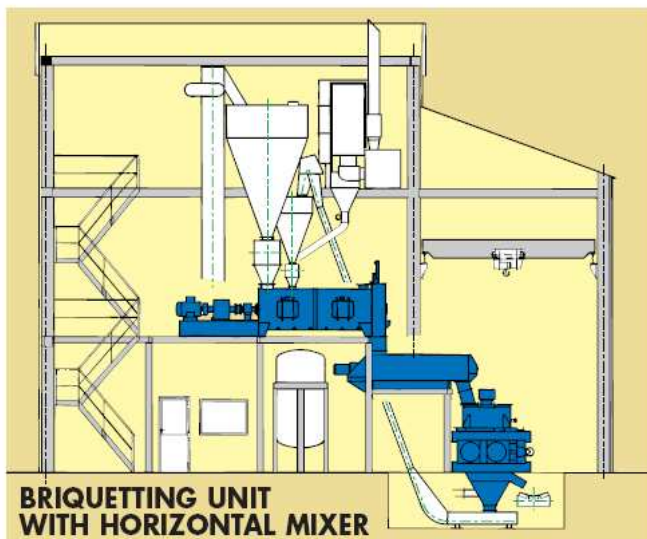
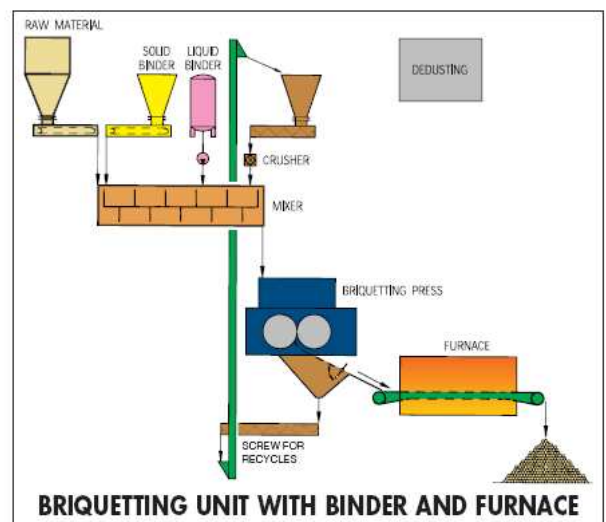

The capacity of a briquetting line can range from 50 kg/h to 100 T/h and for products with a temperature range between -40°C and $+1000^{\circ}\text{C}$.



Fields of application

- Chemicals (sodium carbonate, sodium chloride, sodium sulphate, sodium nitrate, ammonium chloride, iron sulphate, calcium chloride, foundry additives,...)
- Fertilizers (PK, NPK, potassium chloride, potassium sulphate, ammonium sulphate, potassium nitrate, phosphate, potash slag, ...)
- Pharmaceuticals (antibiotics, ...)
- Detergents
- Antioxidants
- Polymers
- Coal or charcoal for production of activated carbon
- Oxides (uranium oxide, chromium oxide, iron oxide, zinc oxide, ...)
- Minerals (lime, dolomite, magnesia, ...)
- Paint pigments
- Nickel ore dust
- Clay
- Dried sewage sludge
- Catalysts
- ...

P R O

Granulation by compaction is a dry process transforming powders into granules of various shapes and dimensions.

Generally, there is no need of a binder for compaction-granulation of powders and the bonding of particles is ensured by the mechanical pressure exerted on the product being compacted. The compacts produced at low or high pressure are in flake form of variable thickness (up to 30 mm).

PROCESS

According to the material and the end-product required, the main stages of the process can be as follows :



C E S S

- A preparation unit for powders (screening-crushing, drying, sieving)
- A weighing and mixing unit of the components
- A compaction unit transforming the powders into flakes ;
- A granulation-screening unit converting the flakes into granules of the required size.
- And for some plants and in particular for the production of compacted fertilizers, a finishing unit with polishing and coating of granules for improved appearance, reduced amount of residual fines and easier storage.

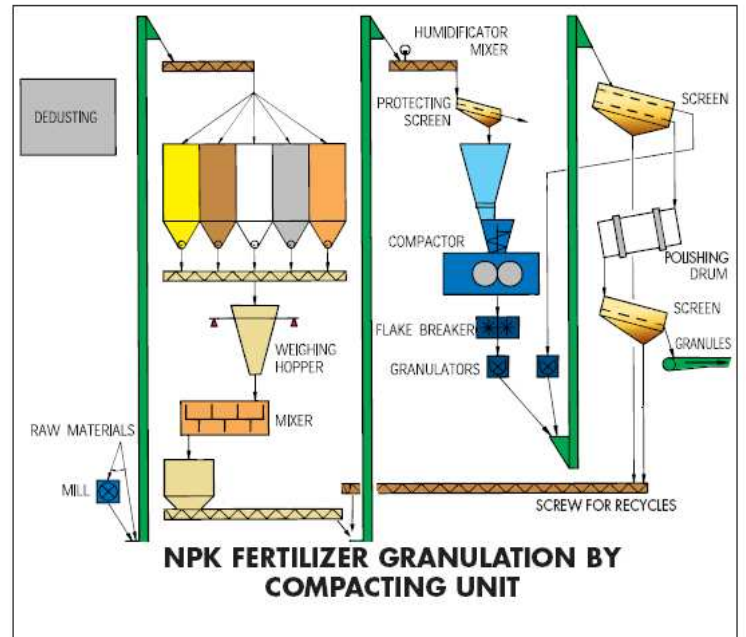

The capacity of such a line can range from 50 kg/h to 50 T/h of granules and for products with a temperature up to 200°C, and over.

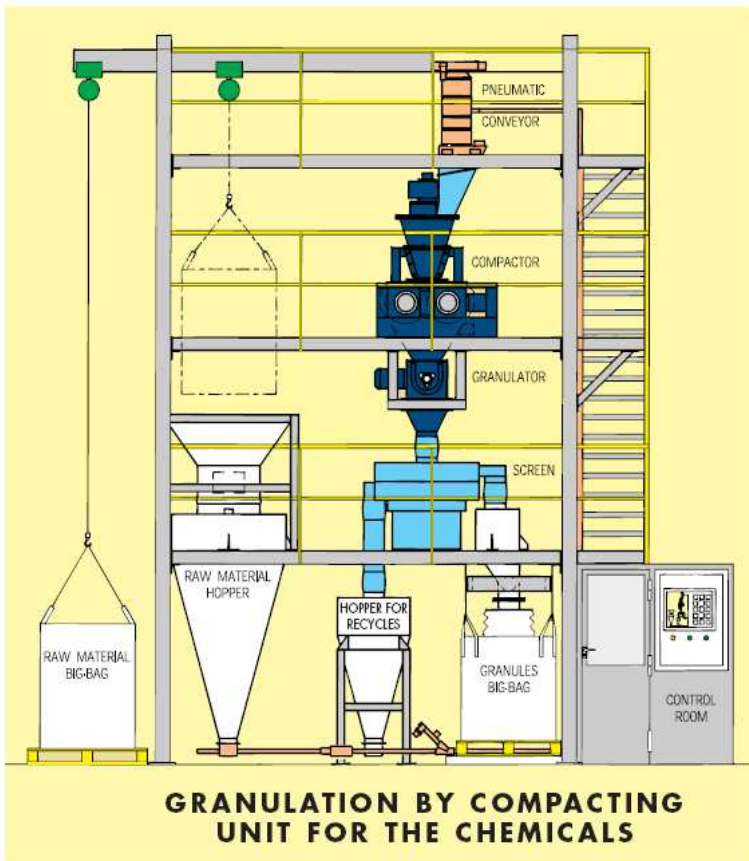

POLISHING DRUM



Fields of application

- Clinker
- Cement raw materials
(limestone, clay)
- Slag
- Titanium oxide
- Minerals
- Synthetic fibers
- ...

P

R

O

From a long experience of design and construction of double roll presses, SAHUT-CONREUR has developed a roller press specifically adapted for grinding.

This machine can crush materials of variable size range. The material fed between the rollers is ground and comes out as friable flakes.

Compared with traditional techniques, the use of this process means :

- energy savings up to 30 % for some materials ;
- throughput increases of crushed end-

product from 30 to 100 % when the process is fitted into an existing grinding circuit.

The roller press can be installed either in a new plant or an existing one.

Compared with the double roll press presented on pages 4 and 5, the following adaptations have been made on the roller press :

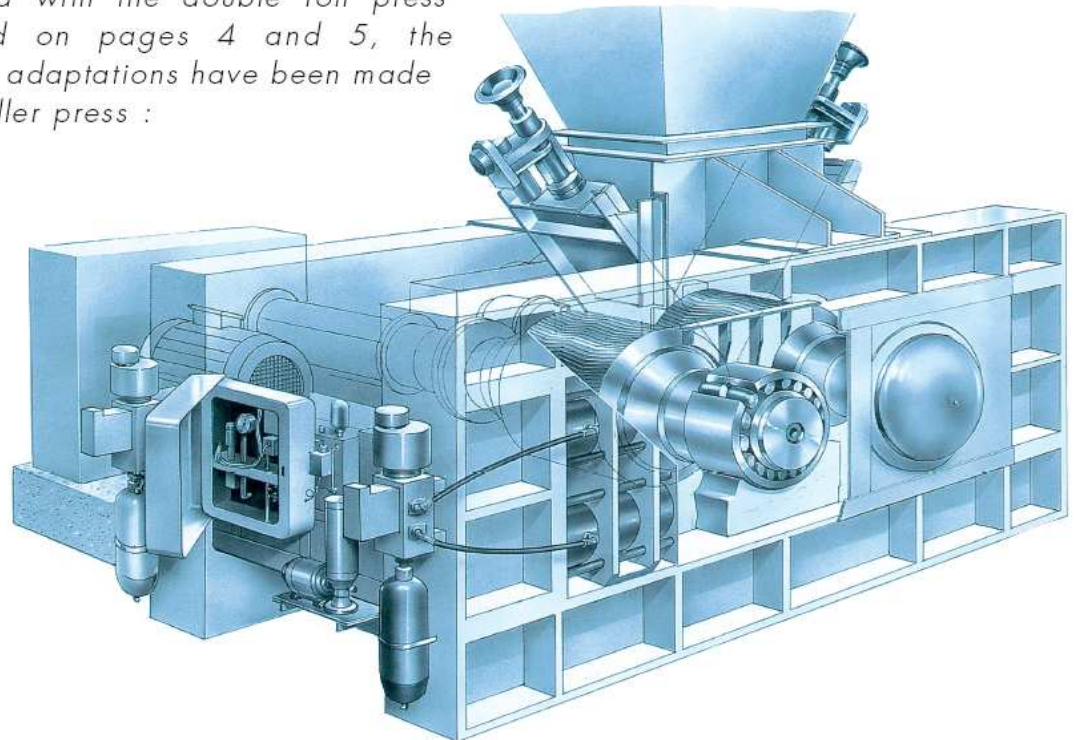

FEED SYSTEM

It is equipped with a hopper fitted with inclined flaps. The manual or automatic adjustment of these flaps enables one to control the flow of material above the rollers.

ROLLERS

Forged steel monobloc rollers with an abrasion resistant working surface (deposit of a baselayer and chevron or straight seams) are usually supplied but other technological solutions (surfaced tyres, bimetal tyres and segments) can be implemented according to the abrasiveness of the feed material.



ROLLER DRIVE

When high-power presses are installed, each roller is driven by a one output gear-box fitted with internal gear couplings which can withstand misalignment. In particular cases (high torque, restricted space, ...) other drive systems (planetary gear-box, hydraulic motor) can be used.



CONTROL - AUTOMATION

Two means of control can be installed on the press :

- either control of power consumed by the roller drive by positioning of the feed flaps ;
- or control of roller gap by positioning of the feed flaps.



Micro-Compactor

SAHUT-CONREUR has developed a range of micro-compactors for laboratory use, Research and Development centers and the pharmaceutical industry as well.

This equipment enables to make briquetting and compaction-granulation feasibility studies on a wide variety of products in very small quantities (about 0,25 liter for one test, a few kg/h in continuous use).

Another advantage of this equipment is that the pieces in contact with the product can be easily and rapidly dismantled, cleaned and reassembled.

These micro-compactors are available in 2 versions :

- the type PB1, made of 2 fixed rolls in translatory movement and without any hydraulic system.
- the type MP1, including a fixed roll, a mobile roll in translatory movement and a hydraulic system.



Simplified Press



For simple applications such as charcoal briquetting or the agglomeration of some chemicals or frozen food, SAHUT-CONREUR has designed several models of simplified presses, in particular without hydraulic system and with both rolls fixed in the press frame.



Pharma Compactor

The PHARMA compactors improve and simplify the dry process granulation for a fair number of applications. It is particularly true when some powders have to be densified or when their compactability or flowability needs improving. This compactor also enables to stabilize mixtures of powders and ensures an easier packaging, handling, storage and/or transport of powders.

SAHUT-CONREUR has developed a range of compactors specifically adapted to the requirements of the pharmaceutical industry : on-line production without dust generation, "production area" fully isolated from the drive system, quick change over of parts in the production area and easy cleaning of these parts, a design and a construction according to the Good Manufacturing Practices (GMP).



The operating conditions are monitored by (gap, strength) sensors. All the elements are controlled by a drive and control system for automation and monitoring of the process as well as logging of data (batch reports) received by a computer.



Crushing/Granulation

The range of crushing/granulation equipment developed by SAHUT-CONREUR is specially adapted to the requirements of the compaction-granulation systems.

These machines are selected according to the physical properties of the product (hardness, abrasiveness, ...), the final size range and the shape of granules required for the marketable product. The yield of a compaction-granulation unit (ratio of the quantity of granules to the quantity of flakes produced by the compactor) is essential : from the compacted flakes, the maximum amount of granules of the right size has to be produced while keeping the amount of fines to a minimum ; these fines will be recycled back to the compactor.

Today SAHUT-CONREUR can propose 7 types of granulators/crushers :

the flake-breaker : it consists of two rotors fitted with toothed discs rotating at the same speed and in reverse direction : the flakes produced by the compactor run through the toothed discs and are reduced in size.



the hammer-mill : it consists of a rotor fitted with mobile hammers and a screen installed under the rotor ; the rotor speed and screen hole size are determined by the product to process and the end size range required.

the oscillating or continuous rotor granulator : the granulator is equipped with a rotor fitted with several arms ; the product is crushed when running through the screen installed under the rotor.

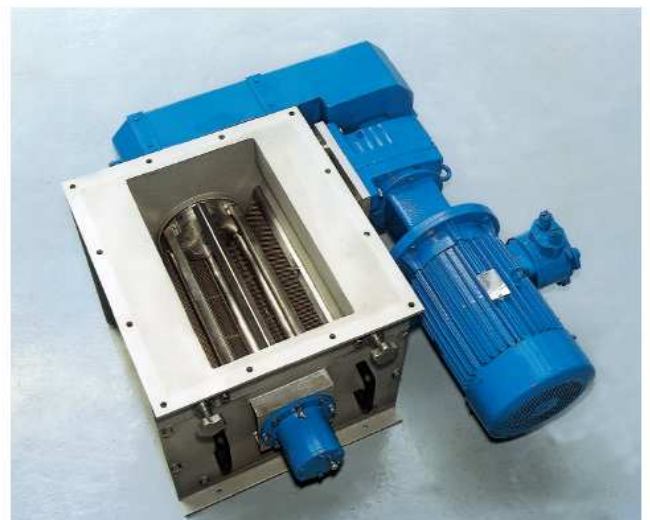

Equipment

the knife crusher :

it consists of two rotors, the working surface of which is machined to obtain either vertical knives or horizontal knives. The product running through the rotors is crushed by the knives. The size range of the crushed material (between 2 and 20 mm) is conditioned by the gap between rotors and the distance between knives.

the smooth roll crusher :

it is well adapted for finer particle size range with an average diameter between 0.3 and 2 mm. With this crusher, the size range can be perfectly targeted while reaching crushing yields vastly superior to the usual yields for such a fine particle size range.



the single-deck grid granulator :

it is equipped with a rotor fitted with several blades and a perforated grid is placed under the rotor.; the rotor rotating at low speed forces the product through the perforations.

Thanks to this grinding technique, the granules have a rounder shape.

Besides, the crushing/granulation yield is higher than the one obtained with the hammer-mill.

The single-deck grid granulator will be installed as primary or secondary granulator.

the double-deck grid granulator :

it includes a primary granulator and two secondary granulators. Taking the throughput of the grid of the secondary granulator into account, the flow of product from the primary granulator is distributed among both secondary granulators mounted in parallel. The aperture of the grid of the secondary granulators can correspond to the upper size requested for the marketable granules : in that case, the upper cloth can be removed and the circulating load in the handling equipment reduced.



Integrated System



SAHUT CONREUR provides compact and complete turn-key systems (including electrical interlocking and interfacing control) integrating other equipment around the press.

These agglomeration and granulation by compacting units are built to meet the customer's specific needs (space available, ...).



SAHUT-CONREUR : the Company

Pilot plant

Customers are free to use the SAHUT-CONREUR pilot facilities in Raismes for any feasibility testing on briquetting, granulation by compacting or grinding of products.

The test lab is equipped with :

- a lab press for feasibility tests on small quantities of product
- a Pharma compactor
- a granulation by compacting unit for pharmaceuticals and chemicals (throughput capacity up to 50 kg/h)
- a granulation by compacting unit (throughput capacity up to 500 kg/h)
- industrial-scale press (throughput capacity up to 9 t/h)
- industrial scale press (throughput capacity up to 15t/h)

It is also equipped with a whole range of machines used in the briquetting, compaction-granulation and grinding processes : dryer, mixers, granulators and screens...

The required testing devices are available to quantify the quality of the finished products.

With all these equipments, all steps of briquetting, granulation by compacting, or grinding processes can be reproduce.



Production plant

The continuous production plant in Raismes is maintained for the production of batches of briquettes or granules (up to a few hundred tonnes) for testing of industrial processes or for potential market testing.

The plant is also available for toll-production.

Engineering and design department



The design of the plants and key-equipment (press, mixer, crusher, granulator, ...) is computer assisted and the process control and automatic control (PID) are also provided by this department. The software used (with bridging with other software) permits the exchange of computer files (drawings and data sheets).

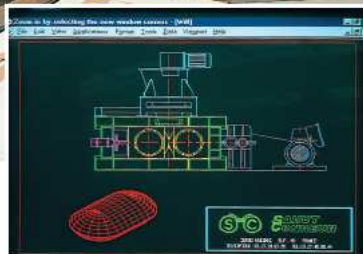

Workshop

Equipped with specific machinery for the manufacture of presses and ancillary equipment, the workshop meets the reliability and quality standards of production and provides a full autonomy to SAHUT-CONREUR.



Services provided by SAHUT-CONREUR

- *Test runs and feasibility studies at the pilot plant.*
- *Custom-made production of batches at the production plant.*
- *Rental of complete units for compaction-granulation of chemicals or pharmaceutical products for testing or for small site productions.*
- *Rental of industrial scale presses and crushers/granulators for industrial site testing.*
- *Basic and detail engineering of briquetting and compaction-granulation units.*
- *Design and manufacture of the key-equipment of these units (press, mixer, crusher, granulator,...).*
- *Technical assistance for mounting and commissioning of the units.*
- *Training of operators.*
- *Supply of spare parts.*
- *Modernization of existing plants and equipment.*
- *Adaptation of SAHUT-CONREUR technology to equipment manufactured by other makers.*

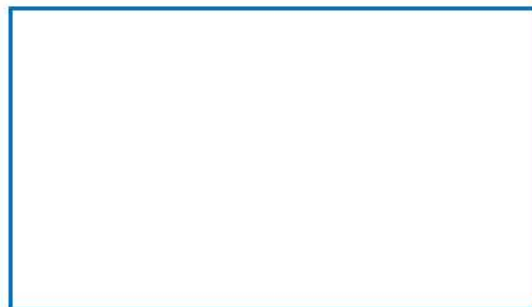

SAHUT-CONREUR

700, rue Corbeau - 59590 RAISMES - B.P. 49 - FRANCE
Tél. 33.(0)3.27.46.90.44 - Fax 33.(0)3.27.29.97.65 - E-mail : sahutconreur@wanadoo.fr
<http://www.sahutconreur.com>